



# SF70 CONICAL FERMENTER

## INSTRUCTIONS



# THANK YOU FOR CHOOSING THE GRAINFATHER SF70 CONICAL FERMENTER

Get familiar with your equipment by following these quick and easy steps on how to assemble and use your SF70. We recommend reading the following safety information before use. Please also find enclosed, advice for cleaning your SF70 Conical Fermenter.

## SAFETY INFORMATION

- Read all instructions before use.
- Always use equipment on a flat and stable surface.
- When the fermenter is full, do not lift it and only wheel it on flat surfaces.
- When equipment is stationary, ensure that the castors are locked into place.
- Ensure that all of the screws and nuts are fully tightened.

**NOTE:** Not following the safety information above could result in serious injuries and may void your product's warranty.

## DIAGRAM & PARTS LIST

- |                                  |                                 |   |
|----------------------------------|---------------------------------|---|
| 1. Air lock                      | 4. Legs                         | 8. Body                                 |
| 2. Bung                          | 5. Dome nuts                    | 9. Thermowell hole                      |
| 3. Thermowell,<br>o-ring and nut | 6. Lid                          | 10. Sample valve,<br>tail piece and nut |
|                                  | 7. Lockable castors<br>(wheels) | 11. Dump valve                          |

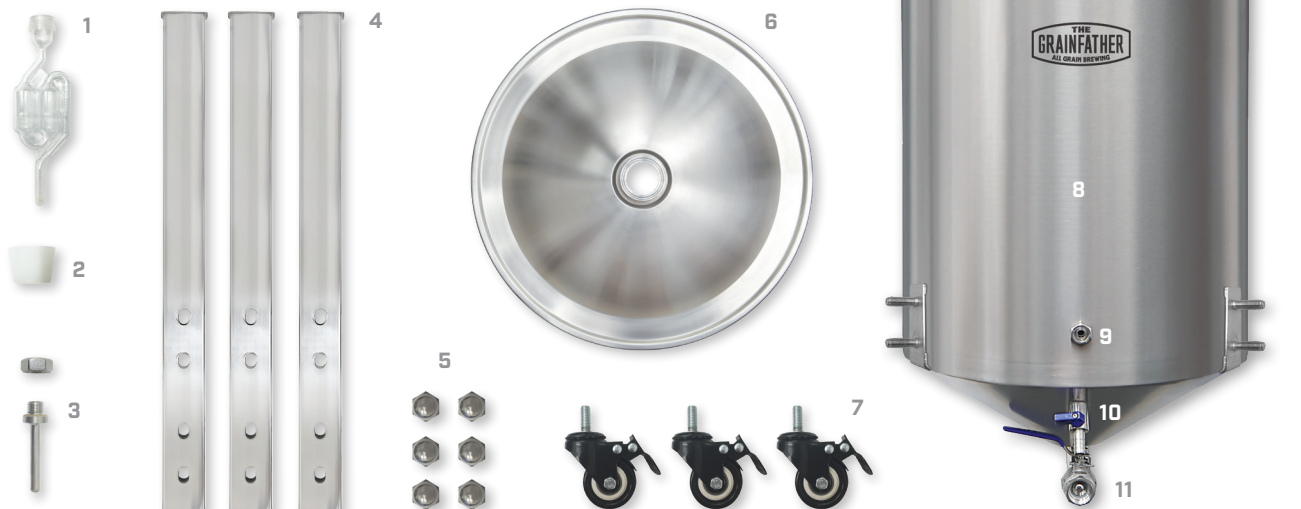

## ASSEMBLY

### ASSEMBLING THE LEGS

1. Remove the large dome nuts from the body of the fermenter.
2. Lay the fermenter gently on its side, using a mat or towel underneath it to avoid scratches.
3. Mount each of the three legs onto the threaded bolts and secure the dome nuts back into place. Ensure that all of the legs are adjusted to the same height.

**NOTE:** Use the extra holes on the leg to adjust the height of your fermenter as shown below.



### ASSEMBLING THE CASTORS (WHEELS)

1. Push the tab down on each of the castors to lock them in place.
2. Lay the fermenter gently on its side, using a mat or towel again to avoid scratches.
3. Screw the castors onto the bottom of the legs.

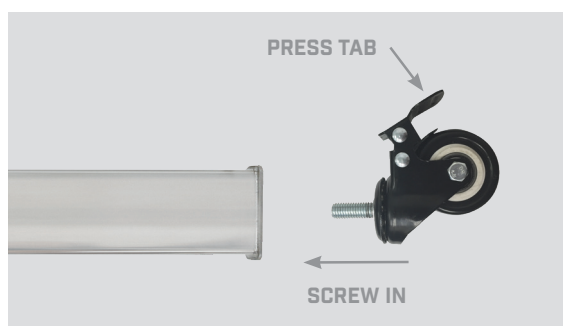

### ASSEMBLING THE THERMOWELL

1. Remove the nut from the thermowell leaving the silicone o-ring in place.
2. From the inside of the fermenter, feed the thermowell through the thermowell hole on the side of the body.
3. Thread the nut back onto the thermowell from the outside of the fermenter and tighten by hand.



## HOW TO USE

Before use, we recommend cleaning your SF70 and all of its components using the Grainfather High Performance Cleaner.

1. Fill the fermenter using a syphon or a counter flow wort chiller if you are using a Grainfather brewing system. Ensure that the volume is at least 40 L.
2. Secure the lid and check that the airlock and bung are still tightly in place.
3. Refer to your recipe for your fermentation temperature and keep the SF70 in a place that will remain close to the temperature required.

**NOTE:** The SF70 can be used in conjunction with the Glycol Chiller Adapter (GCA) Kit for more accurate temperature control during fermentation.

4. Your recipe will also determine the amount of time that your beer needs to ferment. Fermentation is complete once SG readings are stable for two consecutive days.

## TOP TIPS

1. We recommend dumping dead yeast and dry hops from the dump valve every 2-3 days during fermentation. This prevents the yeast and hops from clogging the valve.
2. Throughout fermentation, the sample valve can be used to collect samples and test the gravity of the beer. To do this, open the ball valve and collect the beer in an appropriate vessel.
3. As well as collecting samples, the valve can also be used to transfer the beer after fermentation. Simply connect a hose (10 mm (0.4") inner diameter) to the opening and open the sample valve.

---

## ADVICE FOR CLEANING AND STORAGE

---

1. After fermentation, transfer the beer to a keg or bottles.
2. Rinse out the remaining trub and fill the fermenter halfway with water.
3. Add the required amount of Grainfather High Performance Cleaner to the water and stir to dissolve.
4. Scrub the sides of the fermenter and the lid with a non-abrasive cloth. Ensure that all surfaces have been scrubbed.
5. Rinse and drain out the cleaning liquid using the taps.
6. Remove, disassemble and clean taps.
7. Once all parts are completely dry, reassemble and store.

---

### IMPORTANT SAFEGUARDS:

**READ AND FOLLOW ALL INSTRUCTIONS**

**SAVE ALL WARNINGS AND INSTRUCTIONS FOR FUTURE REFERENCE**

**FOR COMMERCIAL AND FOR INDOOR USE ONLY**

**RESOURCES:** Check out our YouTube Channel for helpful videos. For more information visit our FAQ's page [shop.grainfather.com/index.php/faq](http://shop.grainfather.com/index.php/faq)

### GET IN TOUCH:

Email: [info@grainfather.com](mailto:info@grainfather.com)  
NZ +64 6 888 3027  
AU +61 2 8074 3798  
US +1 (562) 354-4603  
UK/EU +44 1750 432048



Download the FREE  
Grainfather App